

THE SETOFF

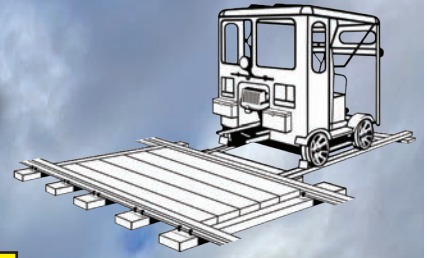

THE OFFICIAL PUBLICATION OF NARCOA
NORTH AMERICAN RAILCAR OPERATORS ASSOCIATION
NOV / DEC 2021 VOLUME 35 - No. 6

A photograph showing a train track curving through a forest with autumn foliage. The view is from the perspective of someone inside a train, looking out the window. The tracks are made of gravel and steel rails, and the surrounding trees are in various shades of yellow and orange. The sky is blue with some clouds.

ANNUAL MEETING
A FAMILY AFFAIR
TURNTABLE RECOMMENDATIONS

NARCOA COMPANY STORE



Online order processing is now available. All our popular items are available for purchase via a typical shopping cart function. Plus, we now accept credit cards for your convenience. Now it is easier than ever to get tools, hardware and all your NARCOA gear. Scan this new QR code with your smartphone or type in the new website address for instant access.

<https://narcoastore.org>



You can still place an order with a personal touch with Dan Page 6432 Mukai Ct., Huntington Beach, CA 92647-6160 Call him at (714) 847-5906 or email dan.h.page@gmail.com



NARCOA Store



NARCOA Safety Hoodie - \$45.00 each + S/H in sizes L, XL, and 2XL and 3XL

NARCOA Hats

Safety yellow with reflectorized trim. One size fits all; embroidered with our logo. \$15 plus \$5 shipping.



NARCOA Logo Patch

Iron or sew it on your favorite jacket or shirt. 4" x 3" \$5 + S/H

Wheel Tools, sold individually or as a set of two profiles and one caliper for \$65+ shipping.

Wheel profile with tape measure slot for gauge dimension. \$12 each + S/H

Wheel thickness calipers, SS with added washers \$45 + S/H

FAQ Brochure

12pack, \$5.00 + S/H

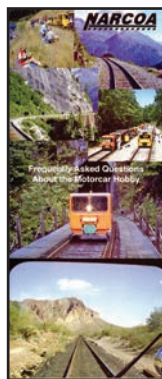

NARCOA Mesh Safety Vest Keep cool in hot weather - \$18.00 each + S/H in sizes M, L, XL, and 2XL and 3XL



Replica Fairmont Padlocks

Made by the original supplier with solid brass cases and shackles, and are keyed alike.

\$29 per pair plus shipping.

PRESIDENT'S MESSAGE

MARK NORTH



Hello out there to my NARCOA friends! I must say that I am personally honored, and I am humbled by the confidence of the Board of Directors appointing me to be president for a second year. My goal as president, is to provide a continued management of NARCOA that evolves the organization where needed but not undoing the successful, well established NARCOA way. It is also important to me and the Board that we continue in a transparent way. The Board of Directors has been, as a group, working hard to be as transparent as possible to the membership and we intend to continue to do so. Again, thank you for the support.

With the unpredictability of life today I am happy to say NARCOA is adapting and looking toward providing excursion opportunities for the membership throughout the country and hopefully back into our neighbor to the north, Canada, next year. With the dedication of team member and Area 3 Director, Brian Davis we held our first successful in-person/zoom hybrid annual meeting. While there are a few learning curves to navigate we are well on our way to providing a forum for all members to participate.

Topics discussed at the annual meeting regarded mostly procedural housekeeping. However, the recommended turntable policy is an important topic to all our operating members. Operators are encouraged to review the recommended policy and apply the proposed equipment changes, as appropriate, to their motorcars. These recommendations are not mandatory, rather strongly encouraged. Ask your Area Director if you have questions and see how other members have adapted their motorcar with the recommended appliances.

Continued on Page 5

FROM THE EDITOR

ROBIN DOUGLAS

The year is winding down and along with this issue you will receive the NARCOA 2022 calendar. It is filled with wonderful images of motorcars on the rails in amazing locations. Thanks to all of you who sent in photos; you made my job easier. If you want an extra copy, they are available at a nominal cost. Please note that there are numerous changes on page 4 both in personnel and contact information.

CORRECTION

In the last issue the cover photo was not attributed to the proper photographer. The caption should have read:

Motorcars running through the fields of Eastern Washington on the Palouse River and Coulee City Railroad. Photo by Trista

Crossley, Wheat Life magazine

The editor deeply regrets this error.



NARCOA Radio Call Sign WPHT745
 Channel 1 – 151.625 MHz
 Channel 2 – 151.505 MHz
 Channel 3 – 158.400 MHz

IN THIS ISSUE

Company Store	2
President's Message	3
From the Editor	3
NARCOA Officials	4
Directors' Messages	5
Safety Update	10
News from Chicago	11
Turntable Recommendations	12
Strasburg Railroad	15
Annual Meeting Minutes	17
Shortlines	23
Upcoming Excursions	24
Suppliers	26
How did you join the hobby?	27

THE SETOFF

VOLUME 35 No. 6

The SETOFF is the official publication of the North American Railcar Operators Association (NARCOA) and is published bimonthly to promote safe legal operation of railroad motorcars, and to encourage fellowship and exchange of information among motorcar enthusiasts.

Robin Douglas, SETOFF Editor
1809 N. Thistle Dr.
Kuna, ID 83634 (661) 713-9295
setoff@centurylink.net

The SETOFF is printed by
Greg Kightlinger, GEK Printing

Membership in NARCOA, which includes a subscription to The SETOFF, is \$40 per year, and is available from the Membership team at the address below. Please send your check made out to NARCOA to:

NARCOA
P.O. Box 9035 Cincinnati, OH 45209
membership@narcoa.org

All subscriptions and address changes must be sent to NARCOA at that address.

All materials for publication must be sent to the SETOFF Editor (master of time, space and ink).

Materials received by the 15th of even numbered months will appear on the 1st of the next odd numbered month subject to editing and available space. Please include your e-mail address and phone number. Electronic submissions are preferred. Text files must have either .doc, docx or .txt extensions. Photo files must be high resolution with .jpg extensions. All materials are archived and not returned. We cannot reprint copyrighted material without written authorization and/or proper attribution.

Letters to the Editor must be signed and include an e-mail address or phone number for authentication. All such letters may be printed as discussed in the NARCOA policy book.

For more information about NARCOA, the safe legal operation of motorcars, or to find NARCOA affiliates located in Canada, the United States, and Mexico, please see: www.narcoa.org

© Copyright 2021 NARCOA. All rights reserved. Reproduction, by any means, in whole or part, by any party, is strictly prohibited.

ON THE COVER:

*Running southbound September 13, 2021 near MP 347 on the Alaska Railroad south of the Denali Park train station.
Photo by Nancy Parsons.*

NARCOA OFFICIALS

President: Mark North
Vice-President: Leland Stewart
Secretary: Bob Hastings
Treasurer: Wayne Parsons

Area 1 Director
(ME, NH, VT, NY, MA, CT, RI)
Tom Sopchak (802) 578-7427
up2665@gmail.com

Area 2 Director
(NJ, PA, DE, MD)
Mark North (302) 378-0745
marknorth15@gmail.com

Area 3 Director
(IN, MI, OH)
Brian Davis (330) 554-4480
briandavis1111@gmail.com

Area 4 Director
(WV, VA, KY, NC, SC, TN, AR)
Jim Hopkins (864) 617-3677
hopkinsjim@bellsouth.net

Area 5 Director
(MS, AL, LA, GA, FL)
Bill Delmar (404) 636-3450
bdelmar.mt19@gmail.com

Area 6 Director
(MN, WI, IL)
Hal Johnson (612) 670-0642
ijigger@gmail.com

Area 7 Director
(ND, SD, NE, IA)
Carl Schneider (515) 967-5181
motorcarlm9@gmail.com

Area 8 Director
(Canada, World outside U.S.)
Lorna Kingsland (905) 895-6213
lornakingsland@rogers.com

Area 9 Director
(CO, KS, MO, NM, OK, TX, UT)
Leland Stewart (210) 863-5397
poppermaker@gmail.com

Area 10 Director
(WA, OR, ID, MT, AK, WY)
Bill Andrews Cell (541) 295-5631
railnsrods@msn.com

Area 11 Director
(CA, NV, AZ, HI)
Steve Paluso
(408) 956-8070
sbpaluso@gmail.com

Director-at-Large (non-voting)
Bob McCoy (360) 790-2943
NPMonad@comcast.net

Director-at-Large (non-voting)
John (Boomer) Schmidt (703) 569-5511
boomerjohn@verizon.net

NARCOA Forum Moderator
Rich Stivers (408) 264-1048
rich@stivers-bros.com

NARCOA Insurance Coordinator
Mike Ford (317) 839-9320
mford@indy.rr.com

NARCOA Treasurer & Insurance Admin.
Wayne Parsons (818) 631-4805
narcoatrea@gmail.com

NARCOA Webmaster
Keith Mackey (352) 347-0770
webmaster@narcoa.org

Operator & EC Qualification Testing
Manager; Company Store Operation
Dan Page (714) 847-5906
dan.h.page@gmail.com

6432 Mukai Ct. Huntington Beach, CA
92647-6160

Committee Chairs:

Affiliates Dave Verzi
wm340@aol.com

HyRail & Custom-Built Motorcars
Tom Falicon raildawg@gte.net

Judiciary
John Gonder (724) 244-7538
up3706@gmail.com

Membership
North & East
Bob Hastings membership@narcoa.org
South
Bill Delmar bdelmar.mt19@gmail.com
West
Dan Page dan.h.page@gmail.com

Nominations & Elections
Bob Hastings narcoelections@gmail.com

Operations and EC Certification
Bill Andrews (541) 295-5631
railnsrods@msn.com

Operator Continual Training
Tom Falicon 828-488-8063
raildawg@gte.net

Operator Mentoring Manager
John Becker (847) 741-6603
jbecker@aol.com

Public Relations
Dan Page dan.h.page@gmail.com

Rules
Leland Stewart (210) 863-5397
poppermaker@gmail.com

Safety
Rich Gunn (916) 687-8510
dblgunn@gmail.com

President's message, continued

Remember, never operate your turntable in a moving motorcar and always stop to inspect your car if your turntable alarm sounds while underway. No one will be upset by this critical momentary safety stop (flag out, of course). Also, Operator Mentoring Manager, John Becker and Operations Chair Bill Andrews are teaming up to create and provide a more consistent mentoring guideline for new NARCOA operators. The goal is to create consistency and ensure the mentoring process does not overlook critical training points presented to new operators.

After the Saturday morning session, I traveled west to Sandwich, Illinois, home of Bob and Laurie Knight. Bob, a past president of NARCOA, who sadly passed away last year, was remembered by local businesses at the Sandwich Fairgrounds with two benches that commemorate him for his enthusiasm for railroading and his local community. It was said that Bob spent many hours in this spot promoting the motorcar hobby. And I believe, even from heaven Bob continues to be an outstanding NARCOA supporter.

Best regards,
Mark

AREA

ONE



TOM SOPCHAK

Radios? Should everyone have one or not? I can tell you that in our first year in the hobby, my wife and I did NOT have one. We were clueless about everything going on around us. Now, as an EC I can't imagine not having one. They are a BIG safety device alerting the operator (and everyone in the motorcar) to everything going on . . . track issues, environment, motorcar break downs, reversing movements, unexpected stops, and much more. Do you absolutely need one? No. There is currently no rule requiring you to have one. That said, I highly recommend having one, or two (a permanently mounted one and a backup portable). Even if your motorcar is an original style picnic table, it's a good idea. As an EC, a radio affords me communication to the pilot, most of the consist, and other EC's at a minimum.

While radios are not very expensive (less than a tank of gas in your truck), they can literal-



ly save you a great deal. As an EC I find them vital in running an excursion, especially a larger excursion. There are new and used ones available on eBay, craigslist and in stores. Before you purchase one, please make sure it will work for NARCOA frequencies. As many members in NARCOA are also amateur radio operators, if you're a radio novice like me, contact your local EC or Area director and ask them for help and direction.

Radios may not be required but they are a critical piece of equipment. Maybe next month I'll get into intercoms.

Tom Sopchak

AREA
FOUR



JIM HOPKINS

I write this message while still traveling toward home from the annual meeting in Chicago. My wife and I use this as a vacation which is needed to get us to look at things beside the interior of our home. It was very good to get to Chicago to see the other members of the board and discuss in person the business of NARCOA.

It was a very good but challenging meeting. The format of a hybrid meeting went surprisingly well. It took getting used to being in a room on a computer with headphones for sure!

As members we all still need to keep our attention to safety while on and off the rails. Use your riders as extra eyes while on the rails. Let them be a part of the crew to watch for the unexpected that may come your way while riding. A safe day on the rails is a really good day.

Jim Hopkins

AREA

SIX



HAL JOHNSON

Forty years ago, a work colleague of mine coined a phrase "people like you, make people like me, like people like you." Corny, isn't it? Well, the guy was a real showman and the phrase fit him to a "T". Step back from the clever wording and examine the real significance of his comment. It's the importance that people have to each other. It's the relationships and camaraderie that exists when people gather for a

common purpose.

That's the real essence of our time together in NARCOA. Whether it's on the rails at an excursion, chatting with the car in front or back while waiting on a siding, enjoying a meal with someone or a group, or sharing "how to" advice on the phone or through the internet, the real benefit of participation in this hobby is through the people we meet along the way.

As a new area director, I have noticed a significant increase in new members here in Illinois, Minnesota, and Wisconsin. This is so refreshing to witness. We most certainly need our long-time members to help guide and open doorways of knowledge to the those who join us. But at the same time, we need the curiosity and energy that new members bring to our hobby. Fresh faces. Fresh ideas. Fresh approaches to complement our rules, procedures, and policies that all help keep us safely on the rails.

In the next SETOFF, as we settle into winter in our neck of the woods, I will introduce the complete list of our new members who have joined us in Area 6 this year. These folks deserve recognition and support, especially over the coming winter as we let mother nature take over and prepare indoors for the new season outdoors in 2022.

In the meantime, be well and be safe. Call or e-mail me with your thoughts if there is anything I can do to help serve your needs. Thank you!

Hal Johnson

AREA

SEVEN



CARL SCHNEIDER

By the time you read this, the rides in Area 7 will have come to an end for 2021. It's been a very good and safe season with several opportunities to enjoy the rails and see all of our friends.

At this writing, we have just returned from the First Iowa Division premier ride on the Black Hills Central Railroad in Hill City, SD. This is always a beautiful excursion with plenty of scenery and wildlife. The runs are planned to give us rail miles while working in conjunction with the steam excursion trains. The schedule worked perfectly; we caused no train delays. The railroad adjusted their train schedule this year so our usual picnic at Oblivion while the train passed had to be set back to mid-afternoon but there were no complaints about eating a little later. It was worth the wait to see that 2-6-6-2 steam up the steep grade while our motorcars were sitting in the clear on the siding.

For those who remember riding with Tom and Sandy Osborne on several FID rides in the past, Wally and I were able to stop by and visit with Sandy at home on our drive back to Iowa. Sandy had been alerted by her son who just happened to see us on our trip to South Dakota, so she came out to the highway by her home and waved as we drove by. We didn't see her in time, but we made sure to stop on our return trip. She's doing well and misses seeing all her friends on the motorcar excursions. She still checks the NARCOA and FID websites online and sends her best wishes to everyone. She also reminded us that she still has seven motorcars in the shop building that she must sell. Sandy was always going to be mentored as an operator but sadly Tom passed away before that could happen.

The 2021 NARCOA annual membership meeting is now history and was successful as our first hybrid in-person and Zoom meeting. This will be the format for the 2022 meeting which is scheduled for Sept. 23 & 24. The hybrid meeting al-

lows for more of the membership to join in right from home via Zoom.

Now that the 2021 ride season is over in most areas of the country, the next few months will be the perfect time to check out your motorcars, so they'll be ready to roll next year. I hope to see many of you on the rails next year.

Carl Schneider

AREA

EIGHT



LORNA KINGSLAND

Hello all. As we progress with pandemic restrictions easing up and more people getting vaccinated here in Ontario, Canada, life in the real world is starting to open up. The USA has said starting in November, they will accept Canadian visitors, even mixed breeds that got doses of two different Covid-19 vaccines, as opposed to a double dose of the same vaccine. Some of our Canadian members have either been busy doing maintenance work on their motorcars, or in the case of some Quebec members, checking out the private organization Les Velorail

in Beaulac-Garthby, Quebec, Canada. This is an organization sponsored by the Province of Quebec that offers rail bikes and hikes along its scenic rail. A few of our motorcar friends were invited to enjoy this scenery recently.

Hopefully with the borders between Canada and the United States opening up more, some of the restrictions of negative Covid tests when entering Canada may also be eased up soon, for those that are double vaccinated. While I chose to attend our annual meeting in Chicago via Zoom, due to the logistics of crossing the border, our former Area 8 Director John Brown had the pleasure of dealing with the bureaucratic red tape of having to prove double vaccination and a negative Covid test upon flying into Chicago and another negative Covid test upon returning to Canada, but he survived. Another reason I chose to remain at home was the fact my husband Grant was officially retiring from his workplace, and I thought it was also important to be around for the celebration of blowing his train whistles at work for his final send off from the power plant he worked in for 38 years.

Maybe in 2022 things will get back to a more normal way of life. I hope everyone is still following their local guidelines for the Covid policies and staying safe. We look forward here

in Canada to being able to get back on the rails by next year. Just a safety reminder to our USA friends to remember that with the fall weather, rails can be damp from the morning dew and may also be covered with leaves; please drive your motorcar in accordance with the conditions and be safe out there as you represent NARCOA.

I would just like to express to some of our newer members to hang in as members, as we navigate through the final stages of the pandemic and hopefully next year we can return safely to the rails and get some of you mentored.

Lorna Kingsland

AREA
NINE

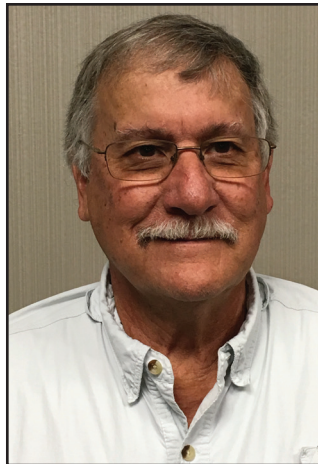

LELAND STEWART

Greetings Area 9,

Time flies when you are having fun. That saying sure applies to this hobby as we are already approaching the end of the season. The Rocky Mountain Division has held a successful and enjoyable excursion on the Leadville, Colorado, and Southern RR in Leadville, CO; as was the Oklaho-

ma Railway Museum's run on the Arkansas and Oklahoma RR in Harrah, OK. By the time you read this, Railroad Partners will have concluded a run on the Llano Branch of CapMetro Transportation. The Oklahoma Railway Museum's 2-day run on the Farmrail RR will also be in the books.

Another recent event was the annual NARCOA meeting in Chicago on October 1 & 2. The meeting was a hybrid meeting with both on-site and Zoom attendees. It was good to see fellow BoD and committee members again after the Covid hiatus of last year. It is an honor and pleasure for me to serve with such a great group of folks who keep NARCOA running smooth and professionally. I encourage you to attend the next meeting or participate via Zoom to see the inner workings of NARCOA firsthand.

Now that winter is approaching, most of us are preparing our motorcars for hibernation. As you put the car(s) away, it is a good idea to do some basic maintenance. Be sure to lube the chassis and bearings to displace moisture and prevent corrosion. It is also a good time to change the engine oil on the four strokes and well as treat the gas. At the same time go over the entire car looking for loose hardware, broken components, and any other issues that came up over the summer runs. Correcting issues now

will eliminate the possibility of overlooking something next spring.

Something else to consider, for motorcars with turntables, is to take a look at the safety overlay recommendations by the Turntable Safety Committee. In particular, the addition of a visible warning light added to the audible alarm circuit to augment the warning for a turntable base that is out of position. Also, a second important recommendation is to assure the power to the turntable is disconnected while under way and that the switch is not within reach or could be accidentally activated by the operator or passengers. These two items alone will add a layer of safety and prevent a contributing factor of recent turntable incidents.

The Turntable Safety Committee has spent a lot of time and research to detail the recommendations for improving the safety for all types of turntables and have published their report in the March/April 2021 issue of *The SETOFF*. While these are currently **strong recommendations**, some may be adopted as rule changes in the future. Please take a look at them and work them into your own application. The winter season is a great time to do these upgrades and assure safe and trouble-free operations.

Lastly, I would like to wish all of you a Happy Thanksgiv-

ing and Merry Christmas. Stay well and safe; I hope to see you soon.

Leland Stewart

AREA TEN



BILL ANDREWS

NARCOA annual Chicago meeting was very productive; Zoom brought us a good number of member participants. The hybrid meeting approach allows opportunities for member comments and questions, increasing our input. Thanks to those who joined in. These minutes are found in this issue.

NARCOA affiliate, Pacific Railcar Operators, (PRO) and our hobby owe so much to retiring members Bill Taylor and Tom Norman. Both PRO Charter members, their leadership and forward thinking shaped not only PRO, but NARCOA as well. Their Montana runs included not only great track and scenery, but examples of outstanding EC skills and scope, including bits of railroad history, Montana history, natural history (watch those rattlesnakes!), and outstanding good times. NARCOA profited im-

measurably from their roles as Area 10 Director and Treasurer, with Jan Taylor as SETOFF editor and EC assistant, and leading PRO as officers. Enjoy the opportunity to continue with your interest in railroad historical societies. We'll be thinking of you!

And Coos Bay Rail Line (CBRL) — WOW!! The Teddy Bear Toy Express was a great success, thanks to operator contributions and great community spirit and leadership! The toy box was overflowing when we arrived in Coos Bay; local Rotary leaders were amazed at our contribution! One could see the sharing spirit run through the consist as we made our first stop to pick up toys! Our outstanding toy box is the result of the generous teamwork including Guy Howard's pushcar donation, rescued from the blackberry bushes and restored by Ralph Burks, the box building skills of Bob McCoy, and painting, design skills of Ralph and Chrystal Burks. You got us off to a great start — many thanks to each of you! Next year will be even more exciting; be sure to come join us!

PRO EC's are tentatively planning next season's runs; weather confines us to a shorter season than we would like. Railroads not recently visited may provide new opportunities next year, so pay attention to the PRO website!

New members and operators joining us on the CBRL run were Russell Homan and Dave Kroesen. They are now hooked on the hobby and planning for next year! Another new member is Daniel Dean from Coos Bay; hope you'll join us on the rail.

A sad note as we lost a very active NARCOA operator and friend, Terry Devine, to illness. A long-time fan of our Coos Bay run, Terry had planned to join us in Oct. We were honored that his wife Mardi, and adult children and friend chose to make the family's final ride with us. PRO was honored to dedicate the run to Terry.

I wish you all a happy, healthy holiday!

Enjoy the ride!

Bill Andrews

SAFETY



RICH GUNN

I've noticed a trend in the last year. Reportable incidents and rear end collisions are down substantially. That's great news and shows that we are all taking a lesson in our safety practices and from our Excursion Coordinators.

Linda and I just finished a remarkable excursion on the Alaska Railroad. Safety was the "name of the game" during our 2 weeks on the rail. We encountered greased rail, wet rail, icy rail – especially in the morning – and there was not a single incident in nearly 1,000 miles of track running. Operating conditions were challenging, and operators are to be commended for "heads up" operating practices. The EC, Dave Balestreri, spent a lot of time in the safety meetings talking about conditions we could expect and reminding operators to be cautious. Early afternoon was another time when we were reminded to be alert and aware of conditions. After a lunch meal and hours of operating it's easy to lose focus.

On a much smaller scale, I attended a run on the Amador Central Railroad shortly after returning home. The infamous "police motorcar" made an appearance on the rail since our other car was still returning from Alaska. The EC on this run, Carl Shellhorn, spent a lot of time talking about safe practices and staying alert. This run involves the crossing of a very busy state highway twice. Flaggers were employed, in addition to the use of signals, to ensure a safe crossing for all. A lot of time was spent in reminding operators and passengers of the need for situational awareness and responsible operating practices.

Speaking of passengers, please remember that they are your extra

eyes and ears while you are operating. It is your responsibility to make sure that these folks are checking for anything that might be a hazard to your operation, especially traffic. It's much better to have more than one set of eyes checking for hazards.

Please spend some time while you are completing your vehicle inspection. I dare say that when the EC reviews the sheets turned in by operators, they will find a lot of check marks in a neat row from top to bottom. Spend some extra time and make sure that your wheels are as they should be. Inspect the profile and look for cracks or other signs of wear. Look at your brake shoes and make sure that you actually see an appropriate thickness of brake shoe. Make sure that your car will not move when the brake lever is set in the first notch. On more than one occasion I have leaned on the back of a parked motorcar with the brake set and found that it will roll.

We're reaching the end of another season of operating our motorcars and we'll soon put them to rest for the winter.

Now is the time to begin planning your maintenance for the "off season." It's time to do all the little things like change the oil, spark plugs and filters. Check your chain, your brake adjustment and the other things that will keep you safe.

As one of our railroad escorts on the Alaska Railroad said, **"Let's go have a good time for a long time."**

NARCOA 2021 ANNUAL MEETING



North also presented the 2021 award to Bill and Nancy Andrews of Oregon. Bill and Nancy have been in the hobby for many years and have developed the Coos Bay Rail Link excursion into one of the finest runs on the West Coast. Bill is the President of Pacific Railcar Operators, the regional NARCOA affiliate in the Pacific Northwest.

NEWS FROM CHICAGO

Hank Brown Award

President Mark North did double duty at this year's annual meeting, presenting two Hank Brown Awards. Normally presented annually, the award for 2020 was delayed due to the pandemic until this year.



Mark presented the 2020 award to Dave and Carol Balestreri of California. Dave and Carol just returned from the Alaska Railway excursion which Dave has EC'd for many years. Dave is also the President of Motorcar Operators West, the regional NARCOA affiliate for California. Dave and Carol live in Sacramento.



Social distancing and masks were the order of the day for all meetings. At left, Brian Davis, our Zoom guru assists Dave Balestreri. John Gonder does his best "Kilroy" impression while presenting from home, as seen above.



Bob Knight Shiny Wheel Award

At the 2021 NARCOA Annual Meeting, Wayne Parsons became the first recipient of the newly established Bob Knight Memorial Shiny Wheel Award. Mark North presented Wayne Parsons with the award for his long-term dedication and service to NARCOA as an Excursion Coordinator, Area Director, and The SETOFF Editor as well as his work in the current positions of Treasurer and Insurance Administrator that Wayne assumed this year

IMPLEMENTING THE NEW TURNTABLE RECOMMENDATIONS BY DAN PAGE

The 2021 March/April issue of The SETOFF included a great article by Brian Davis outlining the NARCOA committee’s work that improved railcar turntables. A vital part of the committee’s work is a table of recommendations. The table appears on page 14 in this edition of The SETOFF for your reference. You can see the full article at:

http://narcoa.memberlodge.org/resources/Documents/Setoff/SO2021/SETOFF_March-April_2021.pdf

My car has an electrically operated turntable, and I wanted to implement the new controls that the committee recommended. My situation falls into the “Electric Driven Jack Screw” column of the committee’s table of recommendations. My friend and Area Director Steve Paluso generously offered to assist me. Steve is a fantastic mechanic and did all the hard work!

The requirements that I needed to address were the turntable master switch and the turntable position alarm. To do this, Steve came up with the design shown here in figure one. The design illustrates the turntable control and warning system.

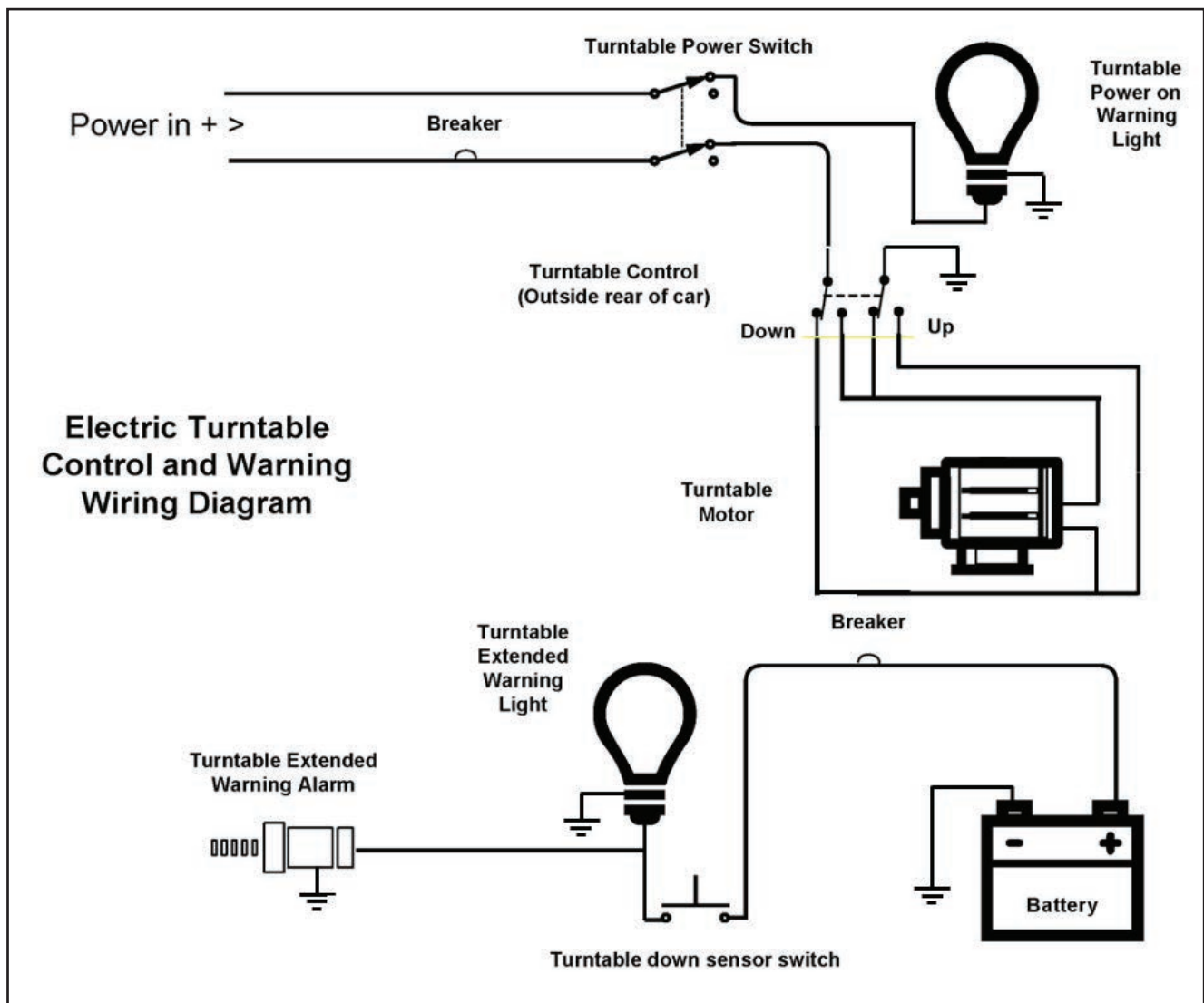

To operate the turntable, I first flip the red turntable power switch ON. The control activates a warning light built into the button and shows me the turntable system is powered on.



Then, I exit the car and operate the switch mounted at the rear of the vehicle. This is the moment in time shown in the drawing. As soon as the turntable begins to descend, the plunger of the Turntable Down sensor switch, usually compressed by the turntable plate in the Up position, extends and closes the circuit on the turntable down alarm system. Inside the car, the alarm and the indicator light (below) activate and operate until the turntable comes back up.



Note that the warning circuit is independent of the turntable motor. This system gives me peace of mind knowing that I will know if, for some reason, my turntable begins to extend while I am inside the car. Additionally, I know that power is not applied to the turntable motor when the switch in the railcar is off. And since the turntable movement control is outside the car, I know I will not inadvertently extend the turntable while going down the tracks.

I want to thank the members of the turntable committee Tom Sopchak (chair), John Gonder, Steve Paluso, Dale Brix, Ed Lee, and Brian Davis, for their work to produce these guidelines.

Parts List and Sources for Turntable Upgrade:

Switch box: <https://amzn.to/2XuUr44>

Dash warning light: <https://amzn.to/2YYblsA>

Dash warning alarm: <https://amzn.to/3lRwaPm>

(Links to Amazon earn a small commission for NARCOA at no cost to you.)

Outside rear switch: <http://fredericksburgshops.com/turntable.html>

Red lighted rocker switch cover with laser etched markings:

Rocker Switch Pros:

https://rockerswitchpros.com/product/custom-rocker-switch-actuator/?attribute_pa_color=red

Custom Actuator

Color: Red

Line 1: TURNTABLE

Bottom lens:

At the bottom, choose Layout 3

Line 2: leave blank

Line 3: WARNING

Symbol: 0125

Line 4: ON

----->At checkout in the Order Notes, request that symbol 0125 be printed inverted



Turntable Safety Feature	Turntable Type			
	Electric Driven (Jack) Screw	Electric Pump Driven Hydraulic Cylinder	Engine PTO Driven Hydraulic Cylinder	Manual Pump Hydraulic Cylinder
Master Electrical Power Switch for Turntable	<ol style="list-style-type: none"> Must have a master power switch that will interrupt all power going to the Up/Down direction switch or to the turntable drive motor. Master power switch must have a Visual Indication when the power circuit is complete (on). This Visual Indicator must be in the operator's normal view at all times. 	<ol style="list-style-type: none"> Must have a switch that will interrupt power to Electric Hydraulic Pump either at the solenoid (low current) OR the main pump power (high current). Master power switch must have a Visual Indication when the power circuit is complete (on). This Visual Indicator must be in the operator's normal view at all times. 	n/a	n/a
Turntable Position Alarm	<ol style="list-style-type: none"> A Visual Alarm and an Audible Alarm must be triggered whenever the turntable is below 2 ½ inches above the railhead. Visual and Audible Alarms must be wired or installed so that there is no way to disable them while the motorcar is in operation. The Visual Alarm must be in the operator's normal view at all times. The Audible Alarm must be sufficiently loud enough to be heard by the Operator during all vehicle operation. 			
Turntable Screw Retention	Early style Electric Turntables with a single attachment bolt must undergo modification (aka Willits Safety Modification)	n/a	n/a	n/a
Up/Down Controls Location	n/a	n/a	<ol style="list-style-type: none"> Controls must be beyond the reach of any person in the motorcar. Must have a physical means to retain position of up/down controls. 	n/a
Up Position Locking Mechanism	It is Recommended that a positive locking mechanism be installed.	Must have a 'positive locking mechanism' to prevent any part of turntable from dropping below 2 ½" above the rail head. (This is Rulebook item 2.13)		
Hydraulic Hose Inspection	n/a	It is Recommended that all hydraulic hoses be inspected routinely for leaks, softness, bulges, worn outer jackets, or other defects which could affect system performance.		
Electric Jack Replacement	It is Recommended that older versions be updated to current standards, or replaced, as there have been significant updates made to the original electric turntable design over the years.	n/a	n/a	n/a

APPALACHIAN RAIL EXCURSION OUTING AT THE STRASBURG RAILROAD



In the cool dawn light of a September morn, with the red zone clear, Tom Healy's motorcar is carefully transferred to the rails. Photo by Tom Healy.



After the safety meeting is conducted, the operators head out on the main line.



The happy operators gather for a group photo to commemorate the day.

*All too soon, it is time to set off, leaving historic number 475 behind in Pennsylvania.
Tom Healy photo*

Photos by Christopher Pollock, except as noted.



NARCOA Meeting Minutes

2021 Annual Member Meeting

October 9, 2021 (Final version)

Note: This annual meeting was a combined in-person and virtual Zoom meeting.

Friday October 1

1. President Mark North called the meeting to order at 8:35 AM CDT. Brian Davis provided technical administration of the Zoom virtual meeting rules
2. Safety Briefing – Mark North identified CPR trained personnel, 911 designated caller, tripping hazards, emergency exit info, and emergency assembly area.
3. Officers & Board of Directors elect in attendance:

Area 1 – Tom Sopchak	Area 2 – Mark North
Area 3 – Brian Davis	Area 4 – Jim Hopkins
Area 5 – Bill Delmar	Area 6 – Hal Johnson - Zoom
Area 7 – Carl Schneider - Zoom	Area 8 – Lorna Kingsland - Zoom
Area 9 – Leland Stewart	Area 10 – Bill Andrews
Area 11 – Steve Paluso	Director-At-Large – Bob McCoy - Zoom
President – Mark North	Vice President – Leland Stewart
Treasurer – Wayne Parsons	Secretary – Bob Hastings
4. Election Results - Seating of new board members-elect (as elected by the membership)
 - a. Area 2 – Mark North (DE, MD, NJ, PA) (re-elected)
 - b. Area 4 – Jim Hopkins (AR, KY, NC, SC, TN, VA, and WV) (re-elected)
 - c. Area 6 – Hal Johnson (IL, MN, and WI) (re-elected) (succeeds Dale Brix)
 - d. Area 8 – Lorna Kingsland (Canada & International) (re-elected)
 - e. Area 10 – Bill Andrews (AK, ID, MT, OR, WA, WY) (re-elected)
5. Seating of Officers – (Previously elected by incoming board via email)
 - a. President – Mark North
 - b. Vice President – Leland Stewart
 - c. Secretary - Bob Hastings
 - d. Treasurer - Wayne Parsons
6. Board of Directors and Committee Chairpersons introduced themselves - All directors and chairpersons introduced themselves and discussed their backgrounds in NARCOA.
7. President’s remarks – Mark North has observed that NARCOA members treat each other like a family, “everybody for everybody.” It has been difficult because of Covid-19. He acknowledged Bob Hastings, Dan Page, Wayne Parsons, Rich Gunn, and Brian Davis as well as the rest of the volunteer staff for their efforts in the past year. Mark North’s number one goal is to provide the safe operation of our railcars. Everything must focus on operating safety. Secondly, the board must continue the effort to be more transparent to the membership on how the organization is operating. Finally, Mark North reported that he had recently spoken with Laurie Knight. He proposed an honorary life membership for Ms. Knight, which the board approved unanimously.

8. Appointment of Directors at Large (DaL)– Appointed by the President - Bob McCoy, John (Boomer) Schmidt. Both DaLs bring many years of experience to NARCOA
9. Sergeant at Arms - Appointed by the President – John Becker
10. Parliamentarian - Appointed by the President – Dan Page (TAB A) – Page reviewed the meeting guidelines.
11. Reappointment of Committee Chairs – Mark North
 - a. Affiliates – Dave Verzi (TAB B) – via Zoom
 - b. Insurance – Wayne Parsons (TAB C)
 - i. The Membership team will remove driver license information from the NARCOA Electronic Database (NED) to eliminate the need for cyber insurance. The year of birth will be added in lieu of the date of birth.
 - ii. Physical motorcar insurance is available. Need better communication of this option. It covers damage during transportation, fire and in storage.
 - c. Treasurer – Wayne Parsons (TAB D) - Discussed in New Business
 - d. Membership and NED – Bob Hastings (TAB E)
 - e. Judicial Committee – John Gonder – via Zoom - discussed in Executive Session
 - f. Safety – Rich Gunn (TAB G) – via Zoom
 - g. Operations Committee – Bill Andrews (TAB H) - Discussed in New Business
 - h. Rules – Leland Stewart (TAB I)
 - i. The SETOFF magazine – Robin Douglas (TAB J)
 - j. Webmaster – Keith Mackey (TAB K) - via Zoom
 - k. Mentoring – John Becker (TAB L)
 - l. Public Relations – Dan Page (TAB M)
 - m. Elections – Bob Hastings (TAB N)
 - n. NARCOA Store – Dan Page (TAB O)
 - o. Online Operator and EC Testing – Dan Page (TAB P)
12. Committee Reports – Brief Q&A on selected topics from written reports provided to the board by the committee chairs.
 - a. Members may obtain a copy of a particular committee report directly from the committee chair. The contact information for the committee chairs is listed on the NARCOA web site under “Documents and Officers”. ***[NOTE: These reports are referenced by TAB letters above. -Ed.]***
 - b. After a discussion of various reports, Brian Davis moved to accept the committee reports, second by Lorna Kingsland, ten (10) BoD members voted in favor of the motion, zero (0) voted against, one (1) abstained – Tom Sopchak. The motion passed approving the committee reports.
13. Approval of Reports of votes taken by the Board of Directors (BoD)
 - a. Final review and approval of reports of board votes concerning action taken in 2021.
 - b. Approval was for both the public report and the private executive report of votes taken by the board.
 - c. Lorna Kingsland moved to accept the public and executive reports, second by Leland Stewart. Ten (10) BoD members voted in favor of the motion, zero (0) voted against, one (1) abstained – Tom Sopchak. The motion passed approving the public and executive reports.

14. Hank Brown Award – Mark North

- a. Mark North presented the 2020 Hank Brown Award for Outstanding service as an Excursion Coordinator to Dave Balestreri of California including the presentation of a plaque, photos, and comments by Balestreri
- b. Mark North presented the 2021 Hank Brown Award for Outstanding service as an Excursion Coordinator to Bill Andrews of Oregon including the presentation of a plaque, photos, and comments by Andrews

Old Business

15. Reducing rear-end collisions – Rich Gunn and John Gonder

- a. Two rear-enders occurred this year which is fewer than previous years. Education is the key. These always occur from lack of attention and are the fault of the operator. One recommendation is to have a quick review after lunch during an excursion. Rear enders tend to occur more frequently after lunch.
- b. There has been positive response to the NARCOA published safety articles. Mark North asked Bill Andrews to send an email to all EC's keeping them informed that excursion coordinators must mention safety at the beginning and end of each morning Safety meeting.
- c. The board voiced concerns about discussing issues at safety meetings because railroad representatives participate in the meetings. Rich Gunn said the discussion should be initiative-taking. Mark North commented that initiative-taking discussions go further with the railroads rather than doing nothing.
- d. Reminders –
 - i. Operators tend to lose focus after lunch. Dave Balestreri mentioned that an after lunch stop to get out to walk around should be encouraged as a best practice.
 - ii. John Gonder mentioned that a high percentage of rear-enders occur when there is more than one person in the car which results in distraction. All participants are part of the crew and must communicate and know how to stop the motorcar.
- e. Brian Davis reminded us to encourage hydration during each excursion.
- f. Plan of action – Mark North wants notes sent to the ECs to communicate best practices. – John Gonder will write the first one.

16. Turntable Committee Update – John Gonder and Tom Sopchak

- a. The committee sent their final report and recommendations to the board two years ago. Tom Sopchak had nothing else prepared for discussion.
- b. The board discussed feedback from the membership. Brian Davis stated that feedback was overwhelmingly positive to add another layer of redundancy to the turntable controls by adding visible warning lights and safety cutoff switches.
- c. Dan Page will write a ‘Setoff’ article defining modifications to his personal motorcar as an example of the proposed changes.
- d. Mark North suggested to make the turntable changes voluntary for one year to avoid uproar and to see how cooperative NARCOA operators are to implement safety improvements without forcing compliance.

- e. Mark North requested a final document with recommendation for the NARCOA rule book change. Dan Page took this action item.
 - f. The board will need a plan for a training video about the new rules.
17. Rule book change: Prohibition of converted All-Terrain Vehicles (ATVs) on excursions – Leland Stewart. There has been no feedback so Stewart will reissue the rule book with the rule to prohibit converted ATVs at NARCOA events
18. Status of Actions to Improve NARCOA Transparency – Bob Hastings will continue publishing executive sessions and the annual meeting on-line as they occur to improve NARCOA transparency. Robin Douglas will continue to publish the annual meeting minutes in The SETOFF.
19. Proposed By-Law Changes – Brian Davis and Bob Hastings (TAB Q)
- a. Increasing the term of elected officers and Directors at Large from one year to two years
 - b. Increasing the pool of eligible candidates to be officers
 - c. Election of unopposed Area Director candidates
 - d. After discussion – the board did not adopt the three proposals.
 - e. The Election Chair will look at developing electronic balloting later this year.
20. Approval of New Affiliate – Dave Verzi informed the board that Rob Piligian has switched from an individual affiliate to Eastern Railcar LLC affiliate. Tom Sopchak moved to accept the change to Eastern Railcar LLC as a new affiliate, seconded by Hal Johnson. Eleven (11) BoD members voted in favor of the motion, zero (0) voted against, zero (0) abstained. The motion passed approving Eastern Railcar LLC as a new affiliate.
21. The New Online NARCOA Store – Dan Page reported on the success and expansion of the NARCOA Store. He identified the advantages of hosting the store as part of the NARCOA Electronic Database (NED) at no additional cost. Also, this adds the ability to accept on-line credit card purchases. He is exploring the possibility of allowing affiliates to consign affiliate items for sale through the store.
22. Succession plan for NARCOA Asset Custodians – Dan Page (TAB R)
- a. We have backups for all key assets.
 - b. Copies of logos are in multiple locations

New Business

23. Use of the term ‘speeder’ in official NARCOA publications – Jim Hopkins
- a. There is a problem with the use of the term “Speeder”. It leaves the wrong impression with the public. NARCOA should use ‘motorcar’ or ‘track vehicle’ as the only descriptors.
 - b. Mark North moved to accept the elimination of the term “speeder” in the future in NARCOA publications, seconded by Jim Hopkins. Eleven (11) BoD members voted in favor of the motion, zero (0) voted against, zero (0) abstained. The motion passed. In the future, NARCOA publications will eliminate the use of the term “Speeder”.
24. NARCOA Public Relations Plan 2021-2022 – Dan Page (TAB S) – Page reviewed the future for the Publicity Chair:
- a. New host Railroads through the American Short Line and Regional Railroad Association (ASLRRRA plan)
 - b. Recruiting new members (Advertising strategy)
 - c. Getting the resources needed (Challenge)

- d. Seven meeting attendees pledged donations totaling \$1400 to help fund the expenses of the Public Relations Plan. Members and affiliates will be solicited for additional donations.
 - e. Dan Page will draft an article for the ‘Setoff’ to make members aware of our future.
25. NARCOA Financials – Wayne Parsons (TAB D)
- a. Overview – the BoD reviewed the 2020 NARCOA Tax Return. Bill Delmar moved to accept the 2020 tax return, seconded by Lorna Kingsland. Eleven (11) BoD members voted in favor of the motion, zero (0) voted against, zero (0) abstained. The motion passed. The board approved the 2020 tax return for filing.
 - b. The present forecast for final 2021 Income and Expenditures will be a \$2000 surplus
 - c. Wayne Parsons discussed the initial budget for 2022.
 - d. Lorna Kingsland moved to accept the Financials as presented, seconded by Mark North.
 - e. Discussion included creating the opportunity to accept contributions from membership. Hal Johnson will develop a plan.
 - f. Leland Stewart proposed investigating a two-tiered membership, postal vs pdf, with an increase for postal ‘Setoff’ memberships.
 - g. Eleven (11) BoD members voted in favor of the motion to accept the Financials, zero (0) voted against, zero (0) abstained. The board approved the financial reports for 2021 and the budget for 2022.

25 1/2. NARCOA Mentoring– Bill and Nancy Andrews (TAB H) - Bill Andrews presented a proposal for a standardized mentoring process for all affiliates. The board set up a task force consisting of Bill Andrews, Gordon Wallick, Carl Shellhorn, John Becker, and John Schmidt, to develop a standardized mentoring process. The board approved and encouraged this proposal by consensus.

[NOTE: The above paragraph was mis-identified as para. 25 section h in the official minutes. Ed.]

26. NARCOA Insurance Late Fee - Wayne Parsons
- a. Wayne Parsons proposed an insurance late fee to encourage the timely application of NARCOA insurance. He proposed a twenty dollar late fee if an existing member submits an insurance application after March 31st of each year. New members would continue to apply during the year that they join.
 - b. After discussion Steve Paluso moved to add a twenty dollar late fee, seconded by Tom Sopchak. Three (3) BoD members voted in favor of the motion, eight (8) voted against, zero (0) abstained. The motion failed. The board did not approve this fee.
27. Timing and location of 2022 Annual Meeting – Bob Hastings
- a. Options for structure of the meeting (In-person, Zoom, Hybrid). Bill Andrews moved to structure a hybrid in-person/Zoom meeting, seconded by Tom Sopchak. Nine (9) BoD members voted in favor of the motion, two (2) voted against (Brian Davis and Hal Johnson), zero (0) abstained. The motion passed. The 2022 meeting will be a hybrid format.
 - b. Options for in-person attendance were all officers, board of directors and chairpersons or limited to officers and board with chairs participating via Zoom. Mark North moved to include officers, board and chairs for in-person attendance if they so choose, seconded by Steve Paluso. Nine (9) BoD members voted in favor of the motion, two (2) voted against (Tom Sopchak and Hal Johnson), zero (0) abstained. The motion passed. The 2022 meeting will include officers, board and chairs for in-person attendance if they so choose.

c. Bob Hastings presented two options for dates for the meeting - September 23-24, 2022, and December 9/10, 2022. Mark North moved to schedule the meeting on September 23-24, 2022, seconded by Leland Stewart. Eleven (11) BoD members voted in favor of the motion, zero (0) voted against, zero (0) abstained. The motion passed. The 2022 NARCOA Member meeting is scheduled for September 23-24, 2022.

d. Bob Hastings presented the initial quote for hosting the meeting at the Sheraton Suites, Chicago. The room rate will increase from the special reduced rate of \$99 plus tax to \$129 plus tax. Mark North moved to schedule the 2022 meeting at the Sheraton Suites Chicago, seconded by Brian Davis. Ten (10) BoD members voted in favor of the motion, one (1) voted against (Tom Sopchak), zero (0) abstained. The motion passed. The 2022 meeting will be at the Sheraton Suites Chicago

e. Bob Hastings will obtain a final quotation from the hotel and will present it to the board for review and approval.

28. Adjournment: The Friday session of the meeting adjourned at 4:55 PM CDT.

29. BoD Executive Meeting – Mark North called this meeting to order at 7:00 PM CDT and adjourned at 8:30 PM CDT.

a. Executive Agenda was distributed separately.

b. Area and At-Large Board of Directors, Judicial Chair, Secretary participated

c. The board reviewed the Judicial Committee report (TAB F – Restricted)

d. The Secretary will distribute the Executive Session meeting minutes separately.

Saturday October 2, 2021

Mark North called the session to order at 9:30 AM CDT.

30. Member's Forum– Mark North opened the floor to discussions with the attending members. Members discussed issues and ideas by Zoom and in-person with the Board of Directors at this time.

31. Discussion Summary – Mark North commented that the board did well covering the agenda and resolving the key agenda items.

32. Ramifications of Minor children participating in NARCOA events – Brian Davis discussed NARCOA insurance liability protection for minors accompanying non-guardians such as grandparents and other temporary guardians. He will continue to work on this issue.

33. Membership report – Bill Delmar observed that there have been 46 new members since June 1st including 32 new members after August 1st. There seems to be a spike in membership as excursions increase.

34. Bob Knight Memorial Shiny Wheel Award – Mark North presented Wayne Parsons with the 'Bob Knight Shiny Wheel' award for long term dedication and duty to NARCOA as Excursion Coordinator, Area Director, and 'Setoff' Editor as well his current position of Treasurer that Wayne assumed this year. The award included the presentation of a plaque, photos, and comments by Parsons.

35. Reminders – Mark North

a. Speaking and posting in public forums

i. Only designated officers may post official responses on public platforms such as social media and news media. Current designees are Mark North and Leland Stewart.

ii. Keith Mackey will add a link to the NARCOA Facebook page on the NARCOA web site.

b. 2021 Meeting Minutes – The 'Setoff' content deadline for Nov/Dec issue is October 10th. Meeting min-

utes must be in final form by October 8th including board approval to publish in the next ‘Setoff’ issue

c. Process Improvement – All job holders should be looking at processes in areas of responsibility to identify areas for improvement. The mentoring procedure development group is a good example of process improvement in NARCOA. Mark North encouraged everyone to work on ideas for process improvement in NARCOA’s operation in the future.

d. Who is your successor? - All NARCOA volunteer job holders should consider identifying members who might be suitable successors for them. It is critical to pass on the institutional knowledge of each position to a succeeding member.

36. Digital Certificate of Permission (CoP) - Tom Sopchak asked about a digital Certificate of Permission form. He asked if we could develop an improved process, i.e.: digital copy. Keith Mackey will develop a digital CoP form and develop an electronic process in coordination with Wayne Parsons.

37. Receipts: Please send travel receipts for reimbursement to Wayne Parsons - 3161 Country Lane, Simi Valley, CA 93063.

38. NARCOA Approach to Corporate RR Conglomerates - Dan Page discussed that the best avenue is through ASLRRRA via the Public Relations Chair.

39. 2022 Member Meeting - Next year’s meeting will be held Friday, September 23rd and Saturday, September 24th, 2022 at the Sheraton Suites Chicago O’Hare, Rosemont, IL and virtually by Zoom.

40. Meeting Adjournment – Steve Paluso moved to adjourn, second by Leland Stewart. Eleven (11) BoD members voted in favor of the motion, zero (0) voted against, zero (0) abstained. Mark North adjourned the meeting at 10:00 AM CDT.

Respectfully submitted,

Robert Hastings - NARCOA Secretary

SHORT LINES

2021’s South Branch Valley Railroad excursion put on by Appalachian Rail Excursions was another wonderful experience that my dad Jim & I look forward to every year. From the amazing scenery along the line, and the familiar friends and faces to share the adventure with, to the good and safe orchestration by the EC’s. By far my all time favorite excursion. - Mike Mullins





NARCOA EXCURSIONS

AS OF OCTOBER 22, 2021



Please submit all excursions and ads directly to
webmaster@narcoa.org
 The *SETOFF* downloads directly from the website
 for the most current information.

Nov 6 - 7 - OK posted 06/07

Farmrail System

Oklahoma Railway Museum two days of runs out of Clinton, Oklahoma on the Farmrail System. Approximately 120 miles per day. Set on fee \$130 covers both days. EC Drake Rice. drake.rice@cox.net Details here:
<https://www.oklahomarailwaymuseum.org/events/motor-car-excursions/>

Nov 6 - 7 - NH posted 09/14

New England Southern/Hobo Railroads

The "Snowflake", former B&M White Mountain Branch, Concord to Lincoln Saturday, return on Sunday. Approx. 140 mile RT. Includes one overnight accommodation per registration at Lincoln. 35 car limit. Fee is \$380. Information <https://www.nerex.org/>
 EC for this NEREX excursion is Gordy Wallick HifihGreen204@msn.com.

Nov 6 - IA posted 02/11

Boone & Scenic Valley Railroad

First Iowa Division - Boone, IA. We will ride the line from Boone to the end of the line at Wolf and back three times during the day and a night run. Round trip mileage is approximately 20 miles. Cost is \$30. EC Carl Schneider motorcarlm9@gmail.com
 Details <http://www.firstiowadivision.com/ride-schedule.asp>

Nov 7 - 8 - NC posted 09/13

Great Smoky Mountains Railroad

102 round trip miles. We will be running from Andrews to Dillsboro on Sunday, stay

overnight in Dillsboro, return to Andrews on Monday. Cost is \$150.00 / EC: Tom Falicon. For information contact: mugzigurl@yahoo.com

Nov 13 - PA posted 08/31

Southwest Pennsylvania Railroad

Please come ride our annual Toys for Tots trip from MT Pleasant to Greensburg and Return . Approx. 50 miles RT Fee is \$60 and a NEW UNWRAPPED TOY. John Gonder, Eric Clark, Chuck Badger excursion coordinators. Details at: <http://areexcursions.com/>

Nov 14 - CA posted 10/22

Placerville and Sacramento Valley RR

Folsom Hampton Station to Latrobe - 20 miles roundtrip. Run fee/\$30 MOW EC John Haverty - cell [916-769-1912](tel:916-769-1912) Details here:
<http://www.mowonline.org/schedule.html#21114>

Nov 20 - PA posted 08/12

North Shore Railroad

86 miles RT from Northumberland to Berwick and return. As part of the fee, please bring a new unwrapped toy for a boy or girl. Bring several if you wish. The public will be invited to see your cars and drop off toys. Registration fee - \$75 EC Larry Maynard. Details <http://www.centralpaexcursions.com/excursions.html>

Nov 21 - PA posted 08/12

Union County Industrial Railroad

30 miles RT from New Columbia to Allenwood to Winfield and return. We will

be stopping at an antique mall on way to Winfield. Registration Fee - \$40 EC Larry Maynard. Details at:

<http://www.centralpaexcursions.com/excursions.html>

Dec 3 - 5 - FL posted 01/05

Florida Central RR, Florida Northern RR

Friday from Eustis to Mt Dora - total about 15 miles. Saturday, Eustis to Winter Garden and return - about 65 miles. Sunday from Ocala to Candler and return - about 30 miles. Cost \$175. EC Keith Mackey kjm900@gmail.com South Eastern Railcar Operators, Inc. (SERO). Details <https://keithmackey.com/Floridaruns2021.pdf>

Dec 4 - CA posted 07/05

Amador Central Railroad, RRCHS Christmas Toy Run

Weather Permitting. Two runs. This is a NARCOA sanctioned run for motor car operators and their friends and family. Run fee is \$25 if you bring a new, unwrapped toy. Fee \$50 without toys. Prize for the best decorated motorcar. EC Carl Shellhorn [707-695-9722](tel:707-695-9722) cell Chaserskip@Comcast.net

Excursions Held On A Regular Basis

Feb 1, 2021 - Feb 1, 2022

Capitol Metro Transportation

Railroad Partners, Inc. will host NARCOA motorcar runs and work sessions on various dates from Llano, TX to Scobee Spur, TX – Approx. 54 miles RT. Details <http://www.railroadpartners.com/> EC Leland Stewart poppermaker@gmail.com [210-863-5397](tel:210-863-5397)

Feb 1, 2021 - Jan 31, 2022 - PA

Northern Central Railroad

Excursions on the Northern Central Railroad from New Freedom, PA to York, PA on various dates. EC Dean L. Grote call [717-637-7647](tel:717-637-7647) or e-mail for details dizzydean55@embarqmail.com

**Feb 1, 2021 - Jan 31, 2022 - PA
Stewartstown Railroad**

Excursions on the Stewartstown Railroad from New Freedom, PA to Stewartstown, PA on various dates. Northern Central Railcar Association EC Dean L. Grote call [717-637-7647](tel:717-637-7647) or e-mail for details dizzydean55@embarqmail.com

**Feb 1, 2021 - Jan 31, 2022 - GA
Cater Parrott Railnet**

South Eastern Railcar Operators, Inc. will have work sessions on Cater-Parrott Railnet between Madison, GA and Newborn, GA. Barnesville, GA and Thomaston, GA Valdosta, GA and Willacoochee, GA on various dates. EC Frank Ahouse Ahouse.frank@yahoo.com [229-886-4707](tel:229-886-4707)

**Feb 1, 2021 - Jan 31, 2022 - CA
Amador Central Railroad, RRCHS**

RRCHS will be having NARCOA motorcar runs open to all licensed and insured motorcar operators and work parties from Ione to Martell on various dates throughout the year. Details <https://www.amadorcentralrailroad.com/> for information and times/dates on the work parties and runs.

**Feb 1, 2021 - Jan 31, 2022 - GA
St Marys Railroad**

SERO will be having motorcar car runs on the St. Marys RR from St. Marys to Kingsland on various dates. Contact EC Jay Boggs boggsrr@bellsouth.net [904-910-5648](tel:904-910-5648)

SHORT LINES SUBMISSIONS

WANTED & NEEDED

*Simply send your photo(s) and some details as listed in the examples below to:
setoff@centurylink.net*

*Excursion: XYZ Affiliate on 5/10 & 11 2021
(NEREX or MOW for example)*

*Location: Reading, Blue Mountain & Northern's
Pittston Yard (for example)*

Time: Saturday around 5PM

Photographer: you or someone else

*Story: What made this moment interesting to you
and/or what we should know about the photo.*

SUPPLIERS

If you are a supplier of motorcar parts and wish to be included here, please contact the Editor. No endorsement is made of the products, services, or vendors. All listings are for members' consideration only, and are at the discretion of the Editor.

Carburetor rebuilding and parts for F-4,C-5,F-6 and C-8 carburetors. Engine parts for RQ,QBA,ROB,ODB, ROC Frame and some motorcar body parts. Carey Boney & David Eakins, Careyboney@embarqmail.com or Carey Boney, 1605 Powers RD. , Wallace, NC 28466 phone [910-285-7489](tel:910-285-7489).

ThunderHill Services, thunderhillservices@gmail.com and thunderhillservices.com 857-302-3135. Sean McInerney Quality brake assemblies for Fairmont A-3/4/5, S2/ST2, M/MT-14/19, M9 and all Woodings. Oak brake blocks (incl. fasteners) also sold separately. All components manufactured in New England.

Fairmont parts, majority are NOS, all OEM, no reproductions, most came from Brown Railroad Supply – Phil's Motorcar Parts - Operated by Philip Hopper, 6126 Bear Branch Drive, San Antonio, TX 78222, Phone: [210-845-4119](tel:210-845-4119) from 8:00 AM to 6:00 PM, Central Time, weekdays. Personal visit by appointment only. Email at royalrubyman64@gmail.com or visit my website for details on the listings at: <https://www.philsmotorcarparts.com>

Railroad Motor Car Resource Library / Doug Cummins, doug@rrstuff.net 1146 W. 27th St. Independence, MO 64052-3222. Library of rail motorcar manuals, performance sheets, parts lists, maintenance instructions.

H & H Mfg. CO. hhimaparts@aol.com 707-887-7181 Full service machine shop and manufacturer of after-market Fairmont parts. Large supply of new and used Fairmont and Onan parts including transmissions, engines, brake and drive sprockets. Frame and aluminum door and side panels. Assorted rail motorcar project cars for sale.

Fredericksburg Shops, fredshops@earthlink.net or www.fredericksburgshops.com or 209 Creamery Rd., Fredericksburg, Ohio 44627, phone: [330-465-0713](tel:330-465-0713) 2PM-6PM Eastern time. Newly manufactured motor car parts and accessories. Many original producers identified, and their parts are again for sale. Shop also does car repair. Formerly Les King & Company.

Model T coils for 2-cycle cars Improved design Model T ignition coils for all Fairmont 2-cycle motorcar applications. These coils are built inside of a sealed plastic weatherproof case with the proper wiring clips to match the timer clips. These are top quality USA made and will work on either 6 or 12-volt applications. No ballast resistor is required. \$110.00 each. Please add \$10.00 for shipping via priority mail. Fifth Avenue Internet Garage, 415 Court Street, Clay Center, KS 67432. phone [785-632-3450](tel:785-632-3450). fifthaveinternetgarage.com or email fifthavegarage@gmail.com

L&S Speeder Repair and Restoration heatmor@itctel.com 17504 438th Ave., Henry, SD 57243 phone [605-532-3470](tel:605-532-3470). Custom motorcar trailers - will build to your specifications.

Dave Myers at: dave@redspeeder.com or [928-380-7056](tel:928-380-7056) MT-19 Temporary Axle splint. Fairmont transmission sprockets, and special sprockets of interest when re-powering a car with non Onan engines.

Tom Phair tom@phairs.net phone [\(925\) 820-4159](tel:925-820-4159) Complete line of the David Clark Company Intercom systems and railroad type Motorola Radios; new double chain sprocket kits, large inventory of NOS Fairmont parts.

Complete, restorable Fairmont motorcars for sale. Models range from M9 up to A4 including two and four stroke engines, belt and transmission drives. Also parting out several motorcars; please call for more details. David Staggs, [812 545 9684](tel:812-545-9684), Mitchell, Indiana.

Onan CCKB Engine, rebuilt. Onan OEM parts only, no off-shore parts. Built to Onan standard of quality. Built by master engine builder. Shop run-in time 30 minutes. Re-torqued, timing and valves checked. \$1,310.00 with qualified engine exchange. Norm McKeen, text [417-839-3300](tel:417-839-3300).

□ NARCOA does not guarantee, certify or warrant that any mechanical equipment, modification, solution or device described in articles or advertisements in *The SETOFF* are safe or suitable for any member's needs or purposes. Technical articles and product reviews are provided for member's consideration only. Readers are advised to do their own due diligence to determine the safety and suitability of any such equipment, modification, solution, or device for their purposes, and are advised to seek outside expert advice. □

HOW DID YOU GET INTO THE HOBBY?

BY JOHN FOWKES

As with a lot of us, the fascination with trains began early in life, and we share that fascination with friends. So, when a motorcar was discovered by friends (essentially a barn find) I was taken to see it and I thought, I gotta have it! Ownership of the car was determined, and to shorten the story, two friends and I became the owners of a Kalamazoo motorcar. Our intention was to get it running, find an “abandoned” track and go for a ride. This was in the early 1990s, and we knew nothing of NARCOA. Luckily, not one of us got the motorcar operating, and thus we didn’t venture out on “abandoned” track. The motorcar sat in a backyard, getting rustier and rustier.

Fast forward to 2009 (or so). You may have seen the PBS television program entitled California’s Gold, that showcases history and sites of interest in California. One episode was filmed about a group of folks that own and operate railroad motorcars. My wife quite innocently commented “That looks like fun. I would like to do that”. Whereupon I replied, “Well, I do own one”. So, arrangements were made to rescue the Kalamazoo from my friend Chuck’s back yard. The photo is of my sons Greg and Glen standing on each side of Chuck the day we

picked up the Kalamazoo. We brought it home and determined that it was too far rusted away to be salvaged...or so we thought. Then by providence, another motorcar became available to me by means of friends in a Garden Railroad club. The new car, a Fairmont M-19 was purchased and with a bit of spit, polish and a lot of YouTube videos was made to run.

Joining NARCOA, getting mentored and signing up for our first run all happened very quickly. I was soon to learn how helpful NARCOA folks were. Since we had not been exposed to the hobby, my assigned mentor and I spent hours on the phone. We thoroughly discussed all aspects of the hobby. My endless list of questions was patiently answered. We (my sons and I) were encouraged to see how other members have built/alterd their motorcars and trailers to operate safely. It seemed like everyone was eager to share their knowledge.

We had a lot to learn about operating a popper! Our first excursion was a two-day run (Fillmore and Western), and we broke down each day. I thought I was the only person in the organization that had to be towed. My mentor still teases me to let him know when I sign up for a run, so he will spot his car away from mine so as to not have to tow me as much. (In later years, I was fortunate to return the favor for other members.)

Well, the M-19 needed more work than I and my sons knew to do. So I had the car professionally restored. In doing the restoration, Steve Paluso not only sent photos during the rebuild, but would explain what was being done along the way. Steve was quite patient in answering my many questions on motorcar restoration. During the restoration of the M-19, we took a closer look at the Kalamazoo. We determined that it was really just nuts and bolts. Taking lots of



photos during disassembly, we dug in. An internet search revealed that our 'picnic bench' style Kalamazoo was a model 56A (built in 1956) and was offered with front, back, roof and four seats as an option. Being able to take family on a ride was important to us. Greg found a source for a CAD drawing of the front panel. Glen was able to create in CAD a drawing of what the roof must have looked like. As the floorboards were completely rusted out, a local fabricator made



Fairmont M-19 and Kalamazoo K56 at Fillmore & Western RR. (Lettered for a fallen flag RR, the San Pete Valley).

We really enjoy the hobby! We have made runs in California, Oregon, Washington, Idaho, Nevada, Arizona, Colorado, New Mexico and Oklahoma. When on the rails, we enjoy meeting new friends, finding new ways to solve little issues with the cars and in general just enjoying the NARCOA family. It's truly a family affair!



My mechanics Greg and Glen working on the motorcars.

new floors, front, back and roof for us. Greg was learning to weld, so became the chief fabricator. Glen's skills included sourcing parts, drawing needed parts, electrical, etc. But we all worked to get the Kalamazoo together; a true father and sons project.

Greg is much better at running the M-19 than I, and he enjoys it. Glen has not been mentored but enjoys being our traveling mechanic. We have returned to Fillmore and Western with both cars and are thus able to get family members and/or friends in for a ride.



Sandy (wife), me, Greg (son), Annie (future daughter-in-law) and Glen (son) stand in front of Kalamazoo K56A and Fairmont M-19 at Fillmore and Western Railroad.

The California Gold episode on motorcars web address:

<https://blogs.chapman.edu/huell-howser-archives/1997/02/09/railcars-californias-gold-802/>